



Europäisches
Patentamt

European
Patent Office

Office européen
des brevets

Urkunde Certificate Certificat

Es wird hiermit bescheinigt, daß für die in der beigefügten Patentschrift beschriebene Erfindung ein europäisches Patent für die in der Patentschrift bezeichneten Vertragsstaaten erteilt worden ist.

It is hereby certified that a European patent has been granted in respect of the invention described in the annexed patent specification for the Contracting States designated in the specification.

Il est certifié qu'un brevet européen a été délivré pour l'invention décrite dans le fascicule de brevet ci-joint, pour les Etats contractants désignés dans le fascicule de brevet.

Europäisches Patent Nr.

European Patent No.

Brevet européen n°

1164912

Patentinhaber

Proprietor of the Patent

Titulaire du brevet

G. B. D. Corporation
27 King Street, P. O. Box 130
Hamilton, Ontario L0B 1J0/CA

München, den
Munich, le
Fait à Munich, le

27.10.04

EPA/EPO/OEB Form 2031 07.04

Alain Pompidou

Präsident des Europäischen Patentamts
President of the European Patent Office
Président de l'Office européen des brevets

(19)



Europäisches Patentamt
European Patent Office
Office européen des brevets



(11)

EP 1 164 912 B1

(12)

EUROPEAN PATENT SPECIFICATION

(45) Date of publication and mention of the grant of the patent:
27.10.2004 Bulletin 2004/44

(51) Int Cl.7: **A47L 9/00**

(21) Application number: **00900190.0**

(86) International application number:
PCT/CA2000/000016

(22) Date of filing: **07.01.2000**

(87) International publication number:
WO 2000/041454 (20.07.2000 Gazette 2000/29)

**(54) AIR FLOW PASSAGE FOR A CYCLONIC SEPARATOR AND VACUUM CLEANER HAVING SAME
LUFTZUFUHRMITTEL FÜR EINEN ZYKLONENABSCHIEDER UND STAUBSAUGER MIT
DEMSELBEN
PASSAGE DE VEINE D'AIR POUR SEPARATEUR CYCLONIQUE ET ASPIRATEUR MUNI DE CE
PASSAGE**

(84) Designated Contracting States:
**AT BE CH CY DE DK ES FI FR GB GR IE IT LI LU
MC NL PT SE**

- **CONRAD, Helmut Gerhard**
Hampton, Ontario L0B 1J0 (CA)
- **SZYLOWIEC, Ted**
Hampton, Ontario L0B 1J0 (CA)

(30) Priority: **08.01.1999 US 227534**

(74) Representative: **W.P. Thompson & Co.**
Coopers Building
Church Street
Liverpool L1 3AB (GB)

(43) Date of publication of application:
02.01.2002 Bulletin 2002/01

(60) Divisional application:
02078123.3 / 1 297 774

(56) References cited:
EP-A- 0 815 788 **DE-A- 19 506 506**
DE-A- 19 650 407 **FR-A- 1 094 603**
US-A- 3 171 807 **US-A- 4 364 146**
US-A- 4 593 429 **US-A- 5 227 061**
US-A- 5 908 493

(73) Proprietor: **G.B.D. Corporation**
Hampton, Ontario L0B 1J0 (CA)

(72) Inventors:
• **CONRAD, Wayne Ernest**
Hampton, Ontario L0B 1J0 (CA)

EP 1 164 912 B1

Note: Within nine months from the publication of the mention of the grant of the European patent, any person may give notice to the European Patent Office of opposition to the European patent granted. Notice of opposition shall be filed in a written reasoned statement. It shall not be deemed to have been filed until the opposition fee has been paid. (Art. 99(1) European Patent Convention).

Description

FIELD OF THE INVENTION

[0001] The present invention relates generally to cyclonic separators. In one particular application, the invention relates to a vacuum cleaner which uses the cyclonic separation of dirt from an air flow as the primary dirt separation mechanism.

BACKGROUND OF THE INVENTION

[0002] The use of a cyclone, or multiple cyclones connected in parallel or series, has long been known to be advantageous in the separation of particulate matter from a fluid stream. Typically, a relatively high speed fluid stream is introduced tangentially to a generally cylindrical or frusto-conical container, wherein the dirty air stream is accelerated around the inner periphery of the container. The centrifugal acceleration caused by the travel of the fluid in a cyclonic stream through the cyclone causes the particulate matter to be disentrained from the fluid flow and, eg., to collect at the bottom of the container. A fluid outlet is provided for the extraction of the fluid from the centre of the top of the cyclone container, as is well known in the art.

[0003] A typical flow path in a cyclone separator is as follows. Fluid to be treated is introduced tangentially at a fluid inlet located at the upper end of the cyclone container (if the cyclone container is vertically disposed). The fluid stream rotates around the inner surface of the cyclone container, and spirals generally downwardly around the inner surface. At the bottom end of the cyclone container the fluid stream travels radially inwardly, generally along the bottom of the container and then turns upwardly and proceeds vertically up and out of the cyclone container. The particulate matter separating action of the cyclonic flow occurs substantially around the inner surface. Once the air moves inwardly to the centre of the container, and upwardly there through, there is little or no dirt separation achieved.

[0004] Various types of vacuum cleaners are traditionally produced. These include built in vacuum cleaners, canister vacuum cleaners and upright vacuum cleaners. Upright vacuum cleaners have a ground engaging portion (a cleaning head) and an upwardly extending or main body portion. The ground engaging portion typically has wheels for movement of the cleaning head across a floor and a suction inlet for the intake of dirty air into the vacuum cleaner. The upwardly extending portion comprises the filter means for removing dirt which is entrained in the air. The upwardly extending portion generally has a handle for guiding the vacuum cleaner across the floor.

[0005] Traditionally in upright vacuum cleaners, the motor to draw the dirty air through the vacuum cleaner is positioned in the ground engaging head and the upward extending portion is pivotally mounted to the upper

portion of the ground engaging member at a position adjacent the motor.

[0006] The advantages of cyclonic separation have been combined with an upright vacuum cleaner to provide a household cyclonic vacuum cleaner, as shown in U.S. Patent No. 4,593,429 to Dyson. As shown in Figure 1, this vacuum cleaner 10 essentially comprises a large, outer cylindrical cyclone 12, with an inner cyclone 14 nested therein, which is mounted on a floor-cleaning head and provided with a push handle for convenient movement of the unit. A motor, located in the floor cleaning head, draws air through the cleaning head and into an intake conduit 16, which delivers air to the dirty air inlet 18 of the outer cyclone container 12. From the outer cyclone the air flows into inner, nested dust separating cyclone 14, and from there, continues on through the vacuum motor, which is positioned in the ground engaging member, to a clean air exhaust port.

[0007] The air intake conduit 16 connects the floor cleaning head and the dirty air inlet in air flow communication. Air intake conduit 16 extends upwardly along the outside of outer cyclone container 12 generally parallel to the longitudinal axis of the cyclones 12, 14. At a position adjacent air inlet 18 to outer cyclone 12, air intake conduit 16 bends 90° twice to travel inwardly and to provide a tangential air flow to air inlet 18 of outer cyclone container 12.

[0008] In use, air intake conduit 16 may become blocked. If the blockage occurs at a midpoint of the conduit, it may be difficult to clear the blockage. While a clean out port may be provided, the port may not be located near where the blockage occurs. Further, the addition of a port increases the cost and complexity of the manufacture of the product.

[0009] A bend in a conduit for a fluid causes a turbulent pressure loss in the conduit as the fluid travels through the bend in the conduit and the greater the sharpness of the bend, the greater the pressure loss. The pressure loss in the air flow decreases the amount of suction which can be generated at the cleaning head of the vacuum cleaner for any given motor in the vacuum cleaner and therefore the efficiency of the vacuum cleaner.

[0010] Reference is also made to FR-A-1 094 603 which discloses a vacuum cleaner which operates in accordance with the "Tourbillon" principle and in which an inlet pipe carrying dust-laden air passes into a dust receptacle.

[0011] In accordance with the present invention there is provided a vacuum cleaner according to the features of claim 1.

[0012] In one embodiment the cyclone container defines a cyclone chamber having an end distal to the bottom of the cyclone container and the fluid conduit extends longitudinally from a position adjacent the bottom of the cyclone container to a position adjacent the distal end of the cyclone chamber.

[0013] The fluid conduit may extend longitudinally

through the cyclone container.

[0014] In another embodiment the cyclone container has a central portion and the fluid conduit extends through the central portion.

[0015] The fluid conduit may extend coaxially with the axis of the cyclone container.

[0016] In one embodiment the fluid conduit comprises an exit portion which extends within the cyclone container from the central portion outwardly towards the inner surface.

[0017] In one embodiment the fluid conduit is positioned on the outer surface of the wall.

[0018] The fluid conduit may comprise an exit portion which is curved to at least assist in directing fluid tangentially into the cyclone container through the fluid inlet.

[0019] In one embodiment the exit portion includes a curved portion.

[0020] The exit portion may extend substantially horizontally.

[0021] In one embodiment the fluid conduit comprises a longitudinally extending portion and an exit portion which extends within the cyclone container from the longitudinally extending portion outwardly towards the inner surface, the longitudinally extending portion having a curved portion which merges with the exit portion and the fluid inlet is positioned adjacent the inner surface.

[0022] In one embodiment the cyclone container has an outlet having a portion which is removable with the cyclone container and one of the portion of the outlet and a portion of the fluid conduit is nested within the other.

[0023] In one embodiment the vacuum cleaner further comprises an upstream fluid conduit portion positioned exterior to the cyclone container, the fluid conduit is positioned downstream from the upstream fluid conduit portion and the fluid conduit is in air flow communication with the upstream portion when the cyclone container is mounted on the vacuum cleaner.

[0024] The fluid conduit may have an outlet portion, and the outlet portion and the fluid inlet may be configured to redirect air travelling therethrough in a first direction towards the wall and in a second direction to introduce the fluid tangentially to the cyclone container.

[0025] The fluid conduit may be positioned exterior to the cyclone container.

[0026] The fluid conduit may extend linearly.

[0027] The fluid conduit may extend through the cyclone container to an opening in the bottom of the cyclone container and may comprise an air exit for the cyclone container.

BRIEF DESCRIPTION OF THE DRAWINGS

[0028] For a better understanding of the present invention, and to show more clearly how it may be carried into effect, reference will now be made by way of example to the accompanying drawing which show a pre-

ferred embodiment of the present invention, in which:

Figure 1 is a cross-sectional side elevation of an upright cyclonic vacuum cleaner with an air intake conduit according to the prior art;

Figure 2 is a cross-section along line 2 - 2 in Figure 4 of an upright cyclonic vacuum cleaner with an air intake conduit according to the present invention;

Figure 3 is a perspective view of an upright vacuum cleaner according to the instant invention;

Figure 3a is a cross-section along line 3 - 3 in Figure 3 of an alternate preferred embodiment of an upright cyclonic vacuum cleaner with an air intake conduit according to the present invention;

Figure 4 is a cross-section along line 4 - 4 in Figure 2;

Figure 5 is a cross-section along line 4 - 4 in Figure 2 of an alternate preferred embodiment;

Figure 6 is a cross-section along line 6 - 6 in Figure 7 of a further alternate preferred embodiment of the instant invention;

Figure 7 is a cross-section along the line 7 - 7 in Figure 6;

Figure 8 is a cross-section along line 8 - 8 in Figure 9 of a further alternate preferred embodiment of the instant invention;

Figure 9 is a cross-section along the line 9 - 9 in Figure 8;

Figure 10 is a cross-section along line 10 - 10 in Figure 11 of a further alternate preferred embodiment of the instant invention;

Figure 11 is a cross-section along the line 11 - 11 in Figure 10;

Figure 12 is a cross-section along line 12 - 12 in Figure 13 of a further alternate preferred embodiment of the instant invention;

Figure 13 is a cross-section along the line 13 - 13 in Figure 12;

Figure 14 is a cross-section along line 14 - 14 in Figure 15 of a further alternate preferred embodiment of the instant invention;

Figure 15 is a cross-section along the line 15 - 15 in Figure 14;

Figure 16 is a cross-section along line 16 - 16 in Figure 17 of a further alternate preferred embodiment of the instant invention;

Figure 17 is a cross-section along the line 17 - 17 in Figure 16;

Figure 18 is a cross-section along line 18 - 18 in Figure 19 of a further alternate preferred embodiment of the instant invention;

Figure 19 is a cross-section along the line 19 - 19 in Figure 18;

Figure 20 is a cross-section along line 20 - 20 in Figure 21 of a further alternate preferred embodiment of the instant invention;

Figure 21 is a cross-section along the line 21 - 21 in Figure 20;

Figure 22 is an enlargement of the upper portion of the cyclone chamber when positioned in the housing of the vacuum cleaner of Figure 3;

Figure 23 is an exploded view of the cyclone chamber and housing of the vacuum cleaner of Figure 3;

Figure 24 is a perspective view of the cyclone chamber when removed from the housing of the vacuum cleaner of Figure 3;

Figure 25 is an exploded view of the cyclone chamber of Figure 24;

Figure 26 is an enlargement of the upper portion of the downstream portion of the air supply conduit of the vacuum cleaner of Figure 3;

Figure 27 is a top plan view of the upper portion of the downstream portion of the air supply conduit of Figure 26.

Figure 28 is an alternate embodiment of the upper portion of the downstream portion of the air supply conduit of Figure 26;

Figure 29 is a further alternate embodiment of the upper portion of the downstream portion of the air supply conduit Figure 26; and,

Figure 30 and 30a are an embodiment demonstrating the construction of a three dimensional curve according to another aspect of the instant invention.

DETAILED DESCRIPTION OF THE PREFERRED EMBODIMENT

[0029] The following description of improvements in cyclone separators is described in their use with a vacuum cleaner and in particular an upright vacuum cleaner. It will be appreciated that the improvements in cyclonic separators described herein may be used with canister vacuum cleaners, central vacuum cleaners, back pack vacuum cleaners as well as cyclonic separation devices of any sort, including industrial dust collection systems and liquid/liquid, liquid/gas and gas/gas separation systems. For example, they may be used with single or multiple stage of filtration assemblies, and may even be utilized where nested serial cyclones are employed.

[0030] An upright cyclonic vacuum 20 according to the present invention is shown in the Figures 2, 3 and 3a. In the embodiment of Figure 2, the motor is positioned in the cleaning head and the cleaned air is conveyed to the motor for cooling the motor. According to the embodiment of Figures 3 and 3a, the motor is positioned in the upper body portion of the vacuum cleaner. If the vacuum cleaner is a canister vacuum cleaner or a central vacuum cleaner, then the cleaning head may be in air flow communication with the cyclone chamber via a flexible hose.

[0031] Referring to the embodiment of Figure 2, a floor cleaning head 22, which may be any known in the art, is provided at the lower end of cleaner 20. Head 22 comprises a vacuum fan motor 24, a bottom 25 and a transversely extending, floor-contacting rotating brush

member 26 which is connected for rotation to a shaft (not shown) within an opening 27 in bottom 35. Motor 24 provides motive force to rotate brush 26 by means of, for example, a belt (not shown). Mounted on the cleaning head is a housing having a cyclonic dust separation unit, indicated generally at 28. Cyclonic unit 28 may comprise any type of dirt separation cyclone known in the art, e.g. cylindrical or frusto-conical, and may comprise a single stage cyclone or multiple stage cyclone (either in series and/or in parallel). Clean air outlet 40 is in air communication with motor 24 via air exit conduit 41. Upper end 34 of container 30 is sealed, such as by an upper panel 35. A handle 42 and wheels 44 may be provided on cleaner 20 to facilitate movement of the unit for cleaning of a floor, and the like.

[0032] Referring to Figures 3, 3a, 10 and 11, in this embodiment vacuum cleaner 20 has a floor cleaning head 22, means for moving cleaning head 22 across a floor (eg. wheels 44 which may comprise rear wheels or front and rear wheels), a housing 60 rotatably attached to cleaner head 22, and a handle 42 for moving cleaner 20 across the floor. In this embodiment, cleaning head 22 comprises a forward portion 21 and two rear portions 23 extending rearwardly from the forward portion 21. Rear portions 23 are spaced apart and define a space 118 there between. A valve means 68 (eg. a rotatable valve as is known in the art) is provided in cleaning head 22 so as to connect downstream portion 50 of air conduit 46 in air flow communication with upstream portion 48 of air conduit 46 when housing 60 is rotated rearwardly in the direction of arrow B in which position vacuum cleaner 20 is configured for use for cleaning a floor. Housing 60 houses at least one cyclone separator. In this embodiment, cyclonic separator unit 28 uses one cyclone separator, namely container or cyclone bin 30. It will be appreciated that a second stage filtration means, which may comprise a single stage cyclone or multiple stage cyclone (either in series and/or in parallel), may be positioned downstream from container 30 such as in cavity 62. If the second stage filtration means comprises a plurality of cyclones, then the second stage cyclones are preferably in parallel. The treated air travels upwardly from clean air outlet 40 to motor 24 either directly or through a secondary filtration stage which may optionally be positioned in cavity 62. The cleaned air may then exit housing 60 via outlet 116 or it may first optionally pass through chamber 144, which may contain a further filtration means (eg. a HEPATM filter).

[0033] Cyclonic unit 28 comprises at least a first cyclone container or bin 30 having an air inlet 56, preferably at upper end 34 thereof, adapted for providing an air flow tangentially to an inner dirt rotation surface 36 of container 30. Air inlet 56 may be configured to provide an axial flow of air to container 30 and opening 32 at the downstream end of air inlet 56 may have vanes to impart cyclonic flow to the air stream. Preferably, inlet 56 is configured to introduce the air tangentially to container 30. Container 30 also has a dirt collection surface or bottom

38 and a clean air outlet 40.

[0034] In the embodiment of Figure 2, conduit 41 may be positioned exterior to container 30. In a preferred embodiment, conduit 41 is provided on outer surface 37 of container 30 as shown in Figures 4, 18 and 20. In such an embodiment, conduit 41 is preferably provided as a one piece assembly with container 30 (eg. it may be made integrally therewith or it may be made separately and then mounted to outer surface 37 such as by being welded thereto or by being removably attached thereto by mechanical locking means provided on outer surface 37) so that conduit 41 is removable from housing 60 automatically with container 30. Alternately, conduit 41 may be positioned within container 30 (either centrally as shown in Figure 6, or adjacent surface 36 as shown in Figures 8, 12, 14 and 16). Further, the treated air may optionally exit the vacuum cleaner at any desired location if it is not required to cool the motor.

[0035] The air flow path through cleaner 20 commences with an air supply conduit 46 having an upstream portion 48 and a downstream portion 50. Upstream portion 48 is provided in head 22 and has a first end 52 positioned adjacent brush member 26 or the like for receiving the dirt laden air and a distal second end 54. Downstream portion 50 has an upstream end 64 which is positioned in air flow communication with second end 54 and a downstream end 66. Preferably ends 54 and 64 are substantially sealed together to prevent air and dirt leaking there from.

[0036] In one embodiment, upstream and downstream portions 48, 50 may comprise a single member (whether integrally formed or connected together to form a continuous flow path). In such a case, a separated dirt collection means may be positioned below container 30 or portions 48, 50 may be flexible so as to allow cyclone container 30 to be removed from housing 60 and emptied. In another embodiment, upstream and downstream portions 48, 50 are separate elements and downstream portion 50 is removable with container 30 from housing 60 such that portions 48, 50 are in air flow communication when container 30 is mounted in housing 60 of vacuum cleaner 20. Thus, if a blockage develops in conduit 46, by removing container 30 from housing 60 as shown in Figure 23, portions 48 and 50 may be individually accessed at ends 54 and 64 to clean out the blockage.

[0037] As shown in Figures 2, 3, 6, 8, 10, 12, 14 and 16 downstream portion 50 may extend upwardly through container 30. Alternately, as shown in Figures 18 and 20, downstream portion 50 may extend upwardly at a position adjacent outer surface 37 of container 30. Whether downstream portion 50 is provided internally or externally to container 30, by manufacturing the vacuum cleaner so that downstream portion 50 is removable with container 30 from housing 60 (i.e. in a single operation), access is provided at ends 54 and 64 in case of a blockage. Accordingly, multiple access ports are effectively provided as part of the construction of the vac-

uum cleaner. It will be appreciated that downstream portion 50 may be manufactured as part of container 30 (such as by moulding it integrally therewith). Alternately, it may be separately manufactured (such as by extrusion) and subsequently affixed to container 30 by any means known in the art (eg. by welding, engagement of male and female engagement members of the like). In either event, downstream portion 50 and container 30 are a one piece assembly so that when container 30 is removed from housing 60, downstream portion 50 is automatically removed at the same time.

[0038] Downstream portion 50 may enter container 30 at any point (eg. via a side wall) but preferably enters through bottom 38. Further downstream portion 50 preferably extends generally upwardly through the central portion of container 30 which comprises the area occupied by the vertical return path of the fluid as it travels from bottom 38 to outlet 40. As shown in Figures 2 and 3a, downstream portion 50 preferably extends coaxially with the longitudinal axis A of container 30, however, it may be positioned off centre either internal of container 30 (see for example Figure 12) or external of container 30 (see for example Figures 18 and 20). Since downstream portion and container 30 define a complete container for the separated dirt, an advantage of this invention is that, when it is desired to empty container 30, a complete dirt container is removed from the vacuum cleaner in a single step operation.

[0039] Downstream portion 50 is preferably positioned at any location within container 30 where it does not unduly interfere with the cyclonic flow of air within container 30. For this reason, if downstream portion 50 is positioned within container 30, it is preferably centrally located in container 30. In particular, in a cyclone, the air travels generally in an annular band adjacent surface 36 of container 30. The air travels generally downwardly until it reaches a position towards bottom 38 of container 30 at which point the air travels upwardly through the central portion of cyclone container 30. In a most preferred embodiment of this invention, downstream portion 50 is positioned within this central portion of container 30 through which this up flow of air passes.

[0040] As shown in Figures 12, 14 and 16, downstream portion 50 may be positioned adjacent sidewall 36. In such cases, downstream portion 50 is preferably constructed so as to minimize its interference with the flow of air around surface 36. For example, downstream portion 50 may be constructed with rounded surfaces so as to direct the flow of air around downstream portion 50. Further, downstream portion 50 need not be circular in shape but may be elliptical or of other constructions wherein it has a circumferential width (i.e. around inner surface 36) which is substantially greater than its radial width in a direction transverse thereto (i.e. radially inwardly). Thus, downstream portion 50 would extend only slightly into container 30 and would not substantially interfere with the cyclonic flow of air in container 30. If conduit 41 is positioned adjacent inner surface 36, it is

also preferably so shaped. It will be appreciated that downstream portion 50 and conduit 41 may be positioned on opposed portions of inner surface 36 (see Figure 12) or at any other location, such as adjacent each other (see Figure 14).

[0041] In another embodiment, downstream portion 50 and outlet 40 may be nested one within the other. For example, as shown in Figures 6 and 7, downstream portion 50 may be positioned within, and preferably co-axially within, conduit 41. Alternately, conduit 41 may be positioned within, and preferably co-axially within, downstream portion 50. As shown in Figure 16, conduits 41 and 50 may be provided in a nested relationship adjacent surface 36. It will also be appreciated that conduits 41 and 50 may be positioned adjacent each other, for example, adjacent inner surface 36 as shown in Figure 14, or within the central portion of container 30 (not shown). Further, they may be nested within each other or positioned adjacent each other when located adjacent the exterior of container 30 as shown in Figures 18 and 20.

[0042] Air inlet 56 is positioned at the upper end of downstream portion 50. Opening 32 is positioned at the distal end of air inlet 56 from end 66 of downstream portion 50. Air inlet 56 defines the exit portion of the air supply conduit extending longitudinally with the cyclone and may extend along any desired path from downstream portion 50 to opening 32. Preferably, air inlet 56 is wholly positioned within container 30 (eg. it does not exit or enter the container 30 through upper end 34).

[0043] Air inlet 56 may extend at a right angle to downstream portion 50 as shown in Figure 2. Further, it may extend in a straight line to opening 32 as shown in Figure 4. It will be appreciated that opening 32 may be any inlet known in the cyclonic art to introduce air tangentially into a cyclone and it may be positioned at any point along the longitudinal length of container 30 as is known in the cyclonic art.

[0044] Typically vacuum cleaners utilize 90° elbows to redirect an air flow from one plane to a plane at right angles thereto. In particular, the air travels in a first direction when it enters an elbow and then, when it encounters the wall of the elbow, it is directed to travel in a second direction which is at 90° to its first line of travel. The axis of flow of the inlet and the outlet from a 90° elbow are at right angles and exist in a single plane. In order to change the direction of travel of the air into another direction, a second 90° elbow is used. With a cyclone inlet, it is generally necessary to redirect an air flow through two planes (i.e. an axial flow to a lateral flow and the lateral flow to a tangential flow). A first 90° elbow is used to redirect the air from an axial flow to a lateral flow into a cyclone and a second 90° elbow is used to redirect the lateral flow into a tangential flow.

[0045] In one preferred embodiment, air inlet 56 is constructed so as not to have any 90° elbows. Instead, air inlet 56 includes curved portions for redirecting the air so as to impart circular momentum to the dirty air as

it travels there through (as shown in Figure 5) and/or, air inlet 56 includes a curved portion for redirecting the air from an axial flow to flow outwardly to inlet 32 (as shown in Figure 26). By constructing the supply conduit in this manner, 90° elbows are not required to redirect the dirty air to flow outwardly or to redirect the dirty air to enter container 30 tangentially. In a typical application, replacing a 90° elbow with a gradual curved path to redirect the dirty air results in a about a 5 to 10 % reduction in the loss of suction as the air travels through the vacuum cleaner. Thus, a smaller motor may be incorporated into the vacuum cleaner to obtain the same pressure at opening 32 or the suction at end 52 may be increased if the same motor is used.

[0046] Referring to Figure 3a, it will be appreciated that the dirty air travelling in downstream portion 50 must travel outwardly to inlet 56. In the preferred embodiment of Figure 3a, air inlet 56 curves gently from downstream end 66 of downstream portion 50 so as to travel outwardly and generally radially towards opening 32. More preferably, the change in direction of the dirty air from generally vertical to generally horizontal and from generally horizontal to generally tangential occurs so as to reduce the pressure drop during its travel from downstream portion 50 to container 30. Accordingly, the curved portion of inlet 56 is curved to direct the dirty air from travelling generally vertically to generally tangentially. This may be achieved by gradually redirecting the air from a generally vertical flow (assuming the axis A of the cyclone is vertical) to a generally horizontal flow and then from the generally horizontal flow to a generally tangential flow or alternately by gradually redirecting the air from a generally vertical flow (assuming the axis A of the cyclone is vertical) to a generally tangential flow and then from the generally tangential flow to a generally horizontal flow. These redirections may occur sequentially (in either order) or, preferably, at least a portion of these redirections occurs simultaneously to impart a rate of change of direction in the fluid travelling there through in two axis simultaneously. Further the curved portion of the inlet may be a continuous curve so as to continually impart changes to the direction of the dirty air travelling there through or it may have a straight portion incorporated therein. Preferably, it defines a continuously curved member.

[0047] The three dimensional inlet 56 can be considered as an envelope built around a space curve. Every point on the space curve is a centre of the cross section of the envelope built around it. The curve can be defined by $S(x,y,z)$. The curve joins together two points in space not by a straight line but by means of a curve or, preferably a helical curve or other related curve wherein the gradient of the space curve has at least two non-zero components which vary along the arc length of the curve.

[0048] Referring to Figures 30 and 30a, inlet 56 is a duct or conduit comprising an envelope formed by a radius r out from a central space curve 120 having an up-

stream end 122 and a downstream end 124 and which is itself formed about an imaginary cylinder 126. This cylinder is imaginary in the sense that it is used for the purpose of mathematically constructing the conduit. The central space curve 120 begins and ends at the points S1 and S2. The imaginary (construction) cylinder 126 has a radius R. Radii r and R may themselves be varied as functions of (x,y,z) provided that the duct has a radius r where $r < R$ functions. The helical segment of the space curve 120 around which the duct is formed can therefore be defined by $S(t) = (G) \cdot (\cos(t), \sin(t), t) \cdot (x, y, z)$ such that the gradient of the space curve 120 has at least two non-zero components which vary along the arc length of the curve 120. Furthermore, $t_1 < t < t_2$ and $S(t_1)$ is equal to S1 and $S(t_2)$ is equal to S2. The space curve at S1 smoothly becomes a straight line coincident with the construction cylinder's axis C of the construction cylinder. The space curve 120 at S2 smoothly becomes a straight line coincident with the derivative of $S(t)$ at point S2 with respect to the parameter t.

[0049] It will be appreciated that this duct may be used with any fluid stream (liquid or gaseous) and need not be used in association with a cyclone separator. In particular, the three dimensional duct may be used whenever it is desired to alter the direction of travel of a fluid through more than one plane. Thus, the three dimensional duct may be used with a fluid stream that has entrained particulate matter such as a dirty air flow stream to a vacuum cleaner (cyclonic or otherwise) or with a fluid stream which does not contain any material to be separated but is flowing through a system.

[0050] Centrally located in upper end 34 of container 30 is a clean air outlet 40 for permitting withdrawal of air from container 30, as will be described below. From clean air outlet 40, the air flow may proceed, if desired, to a second stage of filtration, such as a second cyclone or other filtration means (not shown). Subsequently, it may be in air flow communication with vacuum fan motor 24 via air exit conduit 41. Head 22 has an exhaust port (not shown) for expelling clean air to the environment.

[0051] In operation, the vacuum fan motor 24 is activated to induce an air flow through cleaner 20. The air flow causes a partial vacuum to form at end 52. Air, and entrained dirt, is drawn into upstream portion 48, with the aid of brush member 26. The dirty air flow moves vertically in downstream portion 50 to opening 32 in air inlet 56 and is introduced tangentially to container 30. The airflow is then accelerated around dirt rotation surface 36, and proceeds generally downwardly along and around dirt rotation surface 36 until it reaches a position towards bottom 38 of container 30, at which point the air flow travels upwardly through the central portion of cyclone container 30. Wall 58 may provide an extension of outlet 40 in container 30. Wall 58 assists in preventing the treated air travelling upwardly to outlet 40 from mixing with the dirty air which is introduced into container 30 via inlet 56.

[0052] As can be seen by a comparison of intake con-

duits 16 and 46, of cleaner 10 and cleaner 20 respectively, the reduction of bends in the air conduit of the present invention beneficially results in a significant reduction in the turbulent pressure loss in the intake conduit, thereby markedly improving the efficiency of the cyclonic separation device as a whole.

[0053] The presence of downstream portion 50 extending through the centre of container 30 interferes minimally with the cyclonic action of the air flow within container 30. Thus the presence of downstream portion 50 does not significantly effect the efficiency of the cyclone.

[0054] The removability of container 30 from housing 60 of vacuum cleaner 20 is more particularly shown by reference to Figures 3a, 22 and 23. Housing 60 comprises a base 72, an upper portion 76 and struts 74 which extend between base 72 and upper portion of housing 76 so as to define a cavity within which container 30 is received. It will be appreciated that housing 60 may be of any configuration which provides an area in which bin 30 may be received. For example, it will be appreciated that if vacuum cleaner 20 is a canister vacuum cleaner, that container 30 may extend horizontally, or at any inclined angle to the horizontal and housing 60 may be of any shape within which container 30 may be received.

[0055] Container 30 may be lockingly received in housing 60 by any means known in the art. In the preferred embodiment, container 30 is provided with a lid 70 which has a recess 80 provided in handle 78 thereof. Container 30 and lid 70 comprise a cyclone chamber which is removably received in housing 60. Lower surface 102 of upper portion 76 of housing 60 is provided with a protrusion 92 which is receivable in recess 80. By moving handle 78 downwardly to the position shown in dotted outline in Figure 22, protrusion 82 is removed from recess 80 allowing bin 30 to be removed from base 72 as is shown in Figure 23. Recess 80 and protrusion 82 are a male and female detent means. It will be appreciated that other male and female detent means or the like which are known in the art may be utilized so that container 30 may be releasably lockingly received in housing 60.

[0056] In the embodiment of Figure 3a, the cleaned air travels upwardly out above container 30. Accordingly, lid 78 is provided with an upper surface 84. Cylindrical wall 58 extends downwardly from upper surface 84. The intersection of upper surface 84 and wall 58 describes opening 40 which is the clean air outlet.

[0057] As can be seen in Figure 23, downstream portion 50 of air supply conduit 46 is removed from housing 60 with container 30. In this embodiment, downstream portion 50 comprises a centre feed tube. Upstream end 64 is removable from downstream end 54. Sealing means, such as O-ring 104 may be provided to join ends 54 and 64 in air flow communication when bin 30 is replaced in housing 60 so as to prevent any leak or any substantial leak where ends 54 and 64 meet.

[0058] Lid 70 may be releasably mounted to container 30 by any means known in the art. Referring to Figure 25, lower end 86 of lid 70 is provided with a recessed surface 90 having two protrusions 92 provided therein. Upper end 88 of container 30 is provided with bayonet mounts 94 for receiving protrusions 92. Accordingly, once container 30 is removed from housing 60, lid 70 is rotated slightly counter clockwise so as to release the bayonet mount whereby lid 70 may then be lifted from container 30 thus allowing container 30 to be emptied.

[0059] As further exemplified in Figure 25, in the preferred embodiment, air inlet 56 is removed with lid 70 from container 30. The construction of air inlet 56 is more particularly shown in Figures 26 - 29. Referring to the preferred embodiment of Figure 26, it can be seen that air inlet 56 comprises a three dimensionally curved member which curves first upwardly and outwardly from centre feed tube 50 through wall 58 into the interior of container 30 which functions as the cyclone chamber. Inlet 56 then continues to curve outwardly and radially so as to provide a tangential air inlet to container 30.

[0060] Downstream end 66 of centre feed tube 50 is in air flow communication with end 106 of air inlet 56. End 106 is provided with a means such as a collar 108 into which end 66 is received so as to join inlet 56 in air flow communication with centre feed tube 50. It will be appreciated that any other means known in the art may be used to join centre feed tube 50 in air flow communication with air inlet 56.

[0061] Referring to Figures 26 and 27, it can be seen that air inlet 56 has a longitudinally extending portion 110 at the end of which is the curved inlet portion which ends at opening 32. In this embodiment, the curved inlet portion comprises a continuous three dimensional curve from upper end 112 of longitudinally extending portion 110 through to the distal end which contains opening 32.

[0062] In a further alternate embodiment, as shown in Figure 29, the distal end of inlet 56 may have an extension member 100 provided on the upper portion thereof. It will be appreciated that extension member 100 may be provided either in the embodiment of Figure 26 or in the embodiment of Figure 28.

[0063] Opening 32 and/or extension 100 may extend horizontally (i.e. in a plane transverse to the longitudinal axis A of container 30). In a preferred embodiment, opening 32 extends downwardly at an angle α of about 1 to about 10°, preferably from about 5 to about 10° from the horizontal. In particular, referring to Figure 28, reference numeral 96 refers to a plane which is at right angles to longitudinal axis A of container 30. Reference numeral 98 defines the axis of opening 32 (i.e. the end portion of curved inlet 56 which extends along axis 98).

[0064] The configuration of the air intake conduit according to the present invention advantageously permits a substantial reduction in the pressure loss experienced in the intake conduit without interfering with the overall performance of the cyclone separation device. Thus, the present invention permits a deeper vacuum to be drawn

at the intake end 52, for a given vacuum motor size. Conversely, the motor size may be reduced in conjunction with the present invention without losing vacuum power over devices having air intake conduits according to the prior art, thereby permitting a comparable vacuum cleaner to be provided at lesser cost.

[0065] In the embodiment of Figure 3a, it will be appreciated that from second end 54, the dirty air travels upwardly through the filtration stages and exits the vacuum cleaner at the top. In particular, the air travels upwardly to air inlet 56 to cyclonic unit 28. The air then travels upwardly from air outlet 40 to the motor and, if desired, further upwardly to a further filtration stage (eg. a HEPA™ filter) which may be positioned in chamber 114 which is provided in housing 60 above motor 24. Regardless of the sequence of the filtration stages, or their number, the air preferably continues to travel generally upwardly from one stage to the next without 90° elbows being required to direct the air flow.

[0066] While the above description constitutes the preferred embodiments, it will be appreciated that the present invention is susceptible to modification and change without departing from the scope of the accompanying claims.

[0067] It will be appreciated that if conduit 41 extends to a position adjacent motor 24, then it is preferably constructed from two portions in a similar fashion to supply conduit 46 such that the upstream portion of conduit 41 is removable with container 30 from the vacuum cleaner and is in air flow communication with the downstream portion of conduit 41 (see for example Figure 6) when container 30 is reinserted into the vacuum cleaner such that the upstream and downstream portions of conduit 41 provide air flow communication for the clean air to travel past the motor to provide cooling therefor.

[0068] It will be appreciated by those skilled in the art that various additions and modifications may be made to the invention and all of these are within scope of the following claims. For example, the cyclone separator may have a hopper of the like provided in one end thereof for channeling the separated particulate matter to a collection chamber positioned external to the cyclone separator or to for other purposes downstream from the cyclone separator.

Claims

1. A vacuum cleaner (20) having a source of dirty air to be treated, the vacuum cleaner comprising:

- a cyclone container (30) having a bottom (38), a wall having an inner surface (36) and an outer surface (37) and a longitudinally extending axis; and
- a fluid inlet (56) to the at least one cyclone container (30);

- characterised by** a fluid conduit (50) integrally formed as part of the cyclone container (30) and which forms part of the air flow path of the vacuum cleaner and in that the cyclone container (30) is removable from the vacuum cleaner.
2. The vacuum cleaner as claimed in claim 1 wherein the cyclone container (30) defines a cyclone chamber having an end (34) distal to the bottom (38) of the cyclone container and the fluid conduit (50) extends longitudinally from a position adjacent the bottom (38) of the cyclone container to a position adjacent the distal end (34) of the cyclone chamber.
 3. The vacuum cleaner as claimed in claim 1 or claim 2 wherein the fluid conduit (50) extends longitudinally through the cyclone container (30).
 4. The vacuum cleaner as claimed in any of claims 1 to 3 wherein the cyclone container (30) has a central portion and the fluid conduit (50) extends through the central portion.
 5. The vacuum cleaner as claimed in any of claims 1 to 4 wherein the fluid conduit (50) extends coaxially with the axis of the cyclone container (30).
 6. The vacuum cleaner as claimed in any of claims 3 to 5 wherein the fluid conduit (50) comprises an exit portion (56) which extends within the cyclone container (30) from the central portion outwardly towards the inner surface (36).
 7. The vacuum cleaner as claimed in any of claims 1 to 3 wherein the fluid conduit (50) is positioned on the outer surface of the wall.
 8. The vacuum cleaner as claimed in any of claims 1 to 7 wherein the fluid conduit (50) comprises an exit portion (56) which is curved to at least assist in directing fluid tangentially into the cyclone container through the fluid inlet.
 9. The vacuum cleaner as claimed in claim 7 wherein the exit portion (56) includes a curved portion.
 10. The vacuum cleaner as claimed in claim 8 or claim 9 wherein the exit portion (56) extends substantially horizontally.
 11. The vacuum cleaner as claimed in any of claims 1 to 6 and 8 to 10 wherein the fluid conduit (50) comprises a longitudinally extending portion and an exit portion (56) which extends within the cyclone container from the longitudinally extending portion outwardly towards the inner surface (36), the longitudinally extending portion (50) having a curved portion which merges with the exit portion and the fluid inlet (56) is positioned adjacent the inner surface.
 12. The vacuum cleaner as claimed in any of claims 1 to 6 and 8 to 11 wherein the cyclone container (30) has an outlet (40) having a portion which is removable with the cyclone container (30) and one of the portion of the outlet and a portion of the fluid conduit is nested within the other.
 13. The vacuum cleaner as claimed in any of claims 1 to 12 wherein the vacuum cleaner further comprises an upstream fluid conduit portion (50) positioned exterior to the cyclone container, the fluid conduit is positioned downstream from the upstream fluid conduit portion (46) and the fluid conduit is in air flow communication with the upstream portion when the cyclone container (30) is mounted on the vacuum cleaner.
 14. The vacuum cleaner as claimed in any of claims 1 to 6 and 8 to 13 wherein the fluid conduit (46) has an outlet portion (56), and the outlet portion and the fluid inlet are configured to redirect air travelling therethrough in a first direction towards the wall and in a second direction to introduce the fluid tangentially to the cyclone container (30).
 15. The vacuum cleaner as claimed in any of claims 1 to 14 wherein the fluid conduit (50) extends along the length of the cyclone container from the bottom (38) to the fluid inlet (56) and communicates with the source of dirty air to be treated and with the fluid inlet.
 16. The vacuum cleaner as claimed in any of claims 1 to 3 or 7 wherein the fluid conduit (50) is positioned exterior to the cyclone container.
 17. The vacuum cleaner as claimed in any of claims 1 to 16 wherein in the fluid conduit (50) extends linearly.
 18. The vacuum cleaner as claimed in any of claims 1 to 5, 7, 12, 16 and 17 wherein the fluid conduit (41) extends through the cyclone container (30) to an opening (40) in the bottom (38) of the cyclone container (30) and comprises an air exit for the cyclone container, such that the fluid conduit is in air flow communication with the cyclone container and with a fluid outlet of the vacuum cleaner.

Patentansprüche

1. Staubsauger (20) mit einer Quelle von zu behandelnder unreiner Luft, wobei der Staubsauger das Folgende umfasst:

- einen Zyklonbehälter (30) mit einem Boden (38), einer Wand mit einer Innenoberfläche (36) und einer Aussenoberfläche (37), und einer sich in Längsrichtung erstreckenden Achse; und
 einen Flüssigkeitseinlaß (56) in den mindestens einen Zyklonbehälter (30); **gekennzeichnet durch** ein Flüssigkeitsschutzrohr (50), das integral als ein Teil des Zyklonbehälters (30) geformt ist und das Teil des Luftweges des Staubsaugers bildet, und **dadurch**, dass der Zyklonbehälter (30) von dem Staubsauger entfernt werden kann.
2. Staubsauger nach Anspruch 1, bei welchem der Zyklonbehälter (30) eine Zyklonkammer mit einem Ende (34) definiert, welches distal zu dem Boden (38) des Zyklonbehälters positioniert ist, wobei sich das Flüssigkeitsschutzrohr (50) in Längsrichtung von einer Position neben dem Boden (38) des Zyklonbehälters bis an eine Position neben dem distalen Ende (34) der Zyklonkammer erstreckt.
 3. Staubsauger nach Anspruch 1 oder Anspruch 2, bei welchem sich das Flüssigkeitsschutzrohr (50) in Längsrichtung durch den Zyklonbehälter (30) hindurch erstreckt.
 4. Staubsauger nach einem der Ansprüche 1 bis 3, bei welchem der Zyklonbehälter (30) einen zentralen Abschnitt umfasst und das Flüssigkeitsschutzrohr (50) sich durch den zentralen Abschnitt hindurch erstreckt.
 5. Staubsauger nach einem der Ansprüche 1 bis 4, bei welchem sich das Flüssigkeitsschutzrohr (50) koaxial mit der Achse des Zyklonbehälters (30) erstreckt.
 6. Staubsauger nach einem der Ansprüche 3 bis 5, bei welchem das Flüssigkeitsschutzrohr (50) ein Ausgangsteil (56) umfasst, welches sich innerhalb des Zyklonbehälters (30) von dem zentralen Abschnitt nach aussen in Richtung der Innenoberfläche (36) erstreckt.
 7. Staubsauger nach einem der Ansprüche 1 bis 3, bei welchem das Flüssigkeitsschutzrohr (50) an der Aussenoberfläche der Wand positioniert ist.
 8. Staubsauger nach einem der Ansprüche 1 bis 7, bei welchem das Flüssigkeitsschutzrohr (50) einen Ausgangsabschnitt (56) umfasst, welcher gebogen ist, um die tangentielle Leitung von Flüssigkeit durch den Flüssigkeitseinlaß in den Zyklonbehälter zumindest zu unterstützen.
 9. Staubsauger nach Anspruch 7, bei welchem der Ausgangsabschnitt (56) einen gebogenen Abschnitt umfasst.
 10. Staubsauger nach Anspruch 8 oder Anspruch 9, bei welchem der Ausgangsabschnitt (56) sich im Wesentlichen horizontal erstreckt.
 11. Staubsauger nach einem der Ansprüche 1 bis 6 und 8 bis 10, bei welchem das Flüssigkeitsschutzrohr (50) einen sich in Längsrichtung erstreckenden Abschnitt und einen Ausgangsabschnitt (56) umfasst, welcher sich innerhalb des Zyklonbehälters von dem sich in Längsrichtung erstreckenden Abschnitt nach aussen in Richtung der Innenoberfläche (36) erstreckt, wobei der sich in Längsrichtung erstreckende Abschnitt (50) einen gebogenen Abschnitt umfasst, welcher mit dem Ausgangsabschnitt zusammenläuft, und wobei der Flüssigkeitseinlaß (56) neben der Innenoberfläche positioniert ist.
 12. Staubsauger nach einem der Ansprüche 1 bis 6 und 8 bis 11, bei welchem der Zyklonbehälter (30) einen Auslaß (40) mit einem Abschnitt umfasst, welcher zusammen mit dem Zyklonbehälter (30) entfernt werden kann, wobei ein Abschnitt des Auslasses und ein Abschnitt des Flüssigkeitsschutzrohres ineinander verschachtelt sind.
 13. Staubsauger nach einem der Ansprüche 1 bis 12, bei welchem der Staubsauger weiter einen stromaufwärtigen Flüssigkeitsschutzrohrabschnitt (50) umfasst, welcher ausserhalb des Zyklonbehälters positioniert ist, wobei das Flüssigkeitsschutzrohr stromabwärts von dem stromaufwärtigen Flüssigkeitsschutzrohrabschnitt (46) positioniert ist, und wobei das Flüssigkeitsschutzrohr in Luftflußverbindung mit dem stromaufwärtigen Abschnitt steht, wenn der Zyklonbehälter (30) an dem Staubsauger befestigt ist.
 14. Staubsauger nach einem der Ansprüche 1 bis 6 und 8 bis 13, bei welchem das Flüssigkeitsschutzrohr (46) einen Auslaßabschnitt (56) umfasst, wobei der Auslaßabschnitt und der Flüssigkeitseinlaß für das Umleiten von Luft konfiguriert sind, welche in eine erste Richtung zu der Wand hin durch dieselben hindurchfließt, und in eine zweite Richtung, für das tangentielle Einführen der Flüssigkeit in den Zyklonbehälter (30).
 15. Staubsauger nach einem der Ansprüche 1 bis 14, bei welchem sich das Flüssigkeitsschutzrohr (50) von dem Boden (38) entlang der Länge des Zyklonbehälters bis an den Flüssigkeitseinlaß (56) erstreckt und mit der Quelle der zu behandelnden unreinen Luft und mit dem Flüssigkeitseinlaß verbunden ist.

16. Staubsauger nach einem der Ansprüche 1 bis 3 oder 7, bei welchem das Flüssigkeitsschutzrohr (50) ausserhalb des Zyklonbehälters positioniert ist.
17. Staubsauger nach einem der Ansprüche 1 bis 16, bei welchem sich das Flüssigkeitsschutzrohr (50) linear erstreckt.
18. Staubsauger nach einem der Ansprüche 1 bis 5, 7, 12, 16 und 17, bei welchem sich das Flüssigkeitsschutzrohr (41) durch den Zyklonbehälter (30) bis an eine Öffnung (40) in dem Boden (38) des Zyklonbehälters (30) erstreckt und einen Luftauslaß für den Zyklonbehälter so umfasst, dass das Flüssigkeitsschutzrohr in Luftflußverbindung mit dem Zyklonbehälter und mit einem Flüssigkeitsauslaß des Staubsaugers steht.

Revendications

1. Aspirateur (20) ayant une source d'air sale à traiter, cet aspirateur comprenant :
 - un récipient à cyclone (30) ayant un fond (38), une paroi ayant une surface interne (36) et une surface externe (37) et un axe s'étendant longitudinalement ; et
 - une entrée de fluide (56) vers le au moins un récipient à cyclone (30) ;

caractérisé par un conduit de fluide (50) formé intégralement comme faisant partie du récipient à cyclone (30) et qui fait partie du passage d'écoulement d'air de l'aspirateur et en ce que le récipient à cyclone (30) peut être enlevé de l'aspirateur.
2. L'aspirateur tel que revendiqué dans la revendication 1, dans lequel le récipient à cyclone (30) définit une chambre à cyclone ayant une extrémité (34) distale par rapport au fond (38) du récipient à cyclone et le conduit de fluide (50) s'étend longitudinalement depuis une position adjacente au fond (38) du récipient à cyclone jusqu'à une position adjacente à l'extrémité distale (34) de la chambre à cyclone.
3. L'aspirateur tel que revendiqué dans la revendication 1 ou la revendication 2, dans lequel le conduit de fluide (50) s'étend longitudinalement à travers le récipient à cyclone (30).
4. L'aspirateur tel que revendiqué dans l'une quelconque des revendications 1 à 3, dans lequel le récipient à cyclone (30) a une portion centrale et le conduit de fluide (50) s'étend à travers cette portion centrale.
5. L'aspirateur tel que revendiqué dans l'une quelconque des revendications 1 à 4, dans lequel le conduit de fluide (50) s'étend coaxialement à l'axe du récipient à cyclone (30).
6. L'aspirateur tel que revendiqué dans l'une quelconque des revendications 3 à 5, dans lequel le conduit de fluide (50) comprend une portion de sortie (56) qui s'étend à l'intérieur du récipient à cyclone (30) depuis la portion centrale vers la surface interne (36).
7. L'aspirateur tel que revendiqué dans l'une quelconque des revendications 1 à 3, dans lequel le conduit de fluide (50) est positionné sur la surface externe de la paroi.
8. L'aspirateur tel que revendiqué dans l'une quelconque des revendications 1 à 7, dans lequel le conduit de fluide (50) comprend une portion de sortie (56) qui est courbe pour aider au moins à diriger le fluide tangentiellement dans le récipient à cyclone à travers l'entrée de fluide.
9. L'aspirateur tel que revendiqué dans la revendication 7 dans lequel la portion de sortie (56) comporte une portion courbe.
10. L'aspirateur tel que revendiqué dans la revendication 8 ou la revendication 9 dans lequel la portion de sortie (56) s'étend essentiellement horizontalement.
11. L'aspirateur tel que revendiqué dans l'une quelconque des revendications 1 à 6 et 8 à 10, dans lequel le conduit de fluide (50) comprend une portion s'étendant longitudinalement et une portion de sortie (56) qui s'étend à l'intérieur du récipient à cyclone depuis la portion s'étendant longitudinalement vers l'extérieur vers la surface interne (36), la portion s'étendant longitudinalement (50) ayant une portion courbe qui fusionne avec la portion de sortie et l'entrée de fluide (56) est positionnée à côté de la surface interne.
12. L'aspirateur tel que revendiqué dans l'une quelconque des revendications 1 à 6 et 8 à 11, dans lequel le récipient à cyclone (30) a une sortie (40) ayant une portion qui peut être enlevée avec le récipient à cyclone (30) et une portion, soit la portion de sortie, soit une portion du conduit de fluide, est emboîtée à l'intérieur de l'autre.
13. L'aspirateur tel que revendiqué dans l'une quelconque des revendications 1 à 12, dans lequel l'aspirateur comprend également une portion de conduit de fluide en amont (50) positionnée à l'extérieur du récipient à cyclone, le conduit de fluide est position-

né en aval de la portion de conduit de fluide en amont (46) et le conduit de fluide est en communication d'écoulement d'air avec la portion en amont lorsque le récipient à cyclone (30) est monté sur l'aspirateur.

5

14. L'aspirateur tel que revendiqué dans l'une quelconque des revendications 1 à 6 et 8 à 13, dans lequel le conduit de fluide (46) a une portion de sortie (56), et la portion de sortie et l'entrée de fluide sont configurées afin de rediriger l'air se déplaçant à travers elles dans une première direction vers la paroi et dans une deuxième direction pour introduire le fluide tangentiellement au récipient à cyclone (30).
15. L'aspirateur tel que revendiqué dans l'une quelconque des revendications 1 à 14, dans lequel le conduit de fluide (50) s'étend le long du récipient à cyclone depuis le fond (38) jusqu'à l'entrée de fluide (56) et communique avec la source d'air sale à traiter et avec l'entrée de fluide.
16. L'aspirateur tel que revendiqué dans l'une quelconque des revendications 1 à 3 ou 7, dans lequel le conduit de fluide (50) est positionné à l'extérieur du récipient à cyclone.
17. L'aspirateur tel que revendiqué dans l'une quelconque des revendications 1 à 16, dans lequel le conduit de fluide (50) s'étend linéairement.
18. L'aspirateur tel que revendiqué dans l'une quelconque des revendications 1 à 5, 7, 12, 16 et 17, dans lequel le conduit de fluide (41) s'étend à travers le récipient à cyclone (30) jusqu'à une ouverture (40) dans le fond (38) du récipient à cyclone (30) et comprend une sortie d'air pour le récipient à cyclone, de sorte que le conduit de fluide est en communication d'écoulement d'air avec le récipient à cyclone et avec une sortie de fluide de l'aspirateur.

10

15

20

25

30

35

40

45

50

55

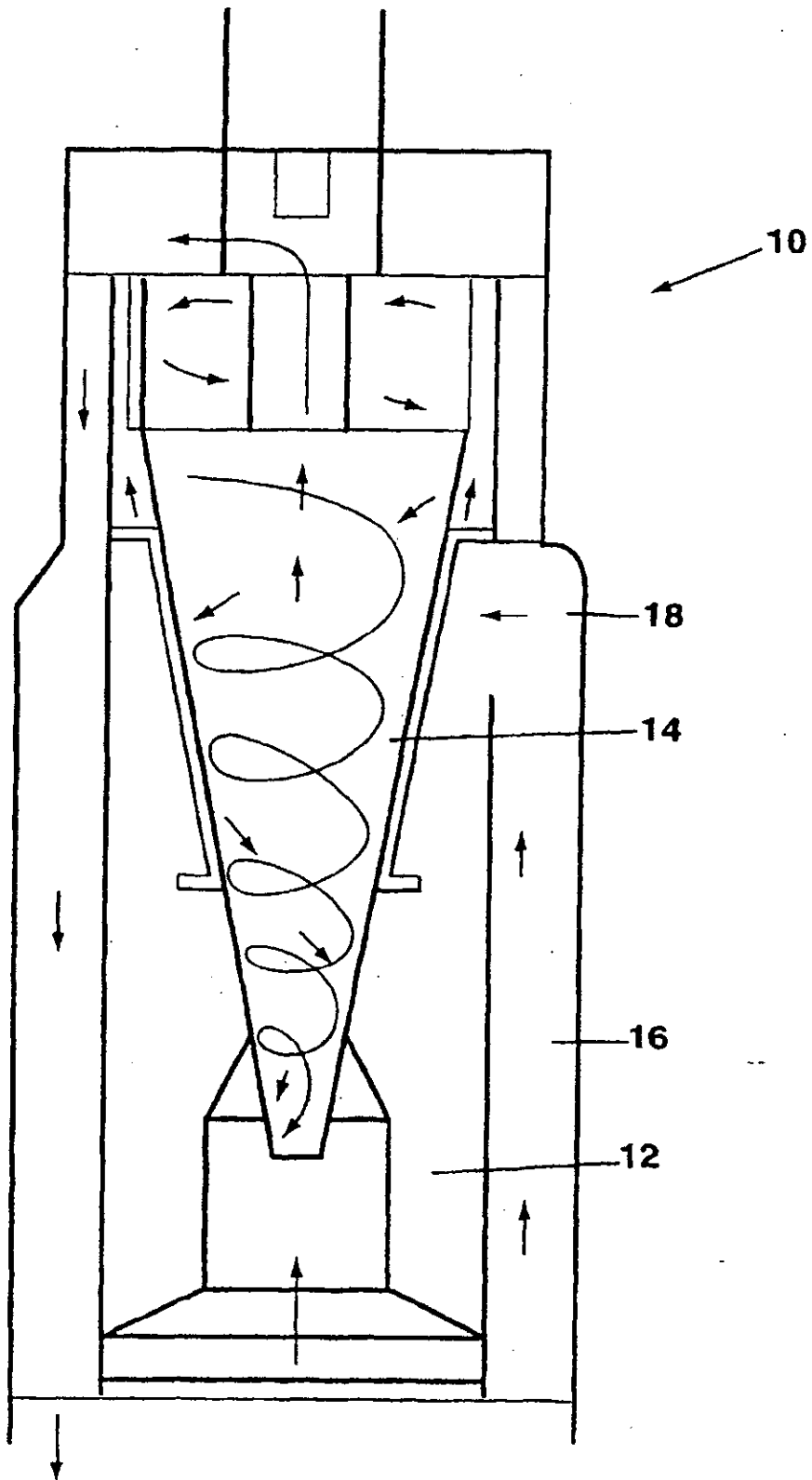

FIG. 1 (Prior Art)

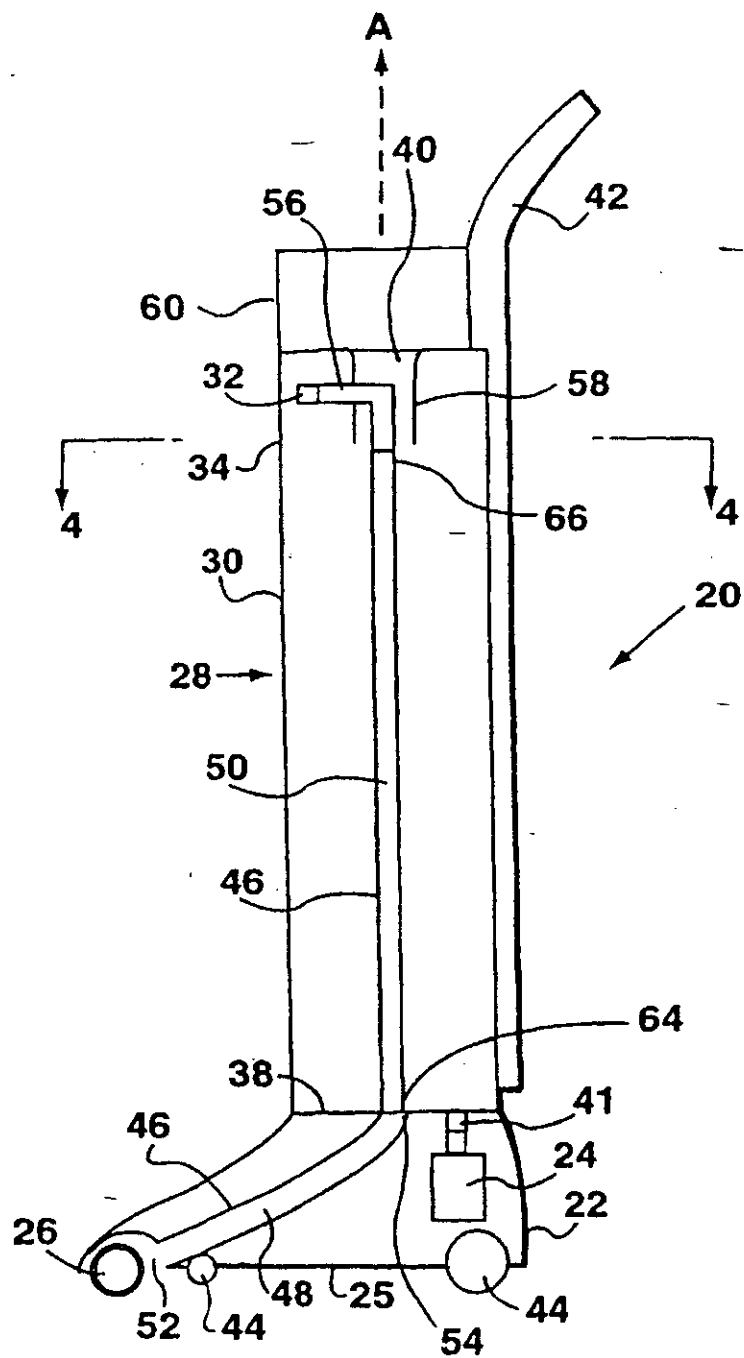

FIG. 2

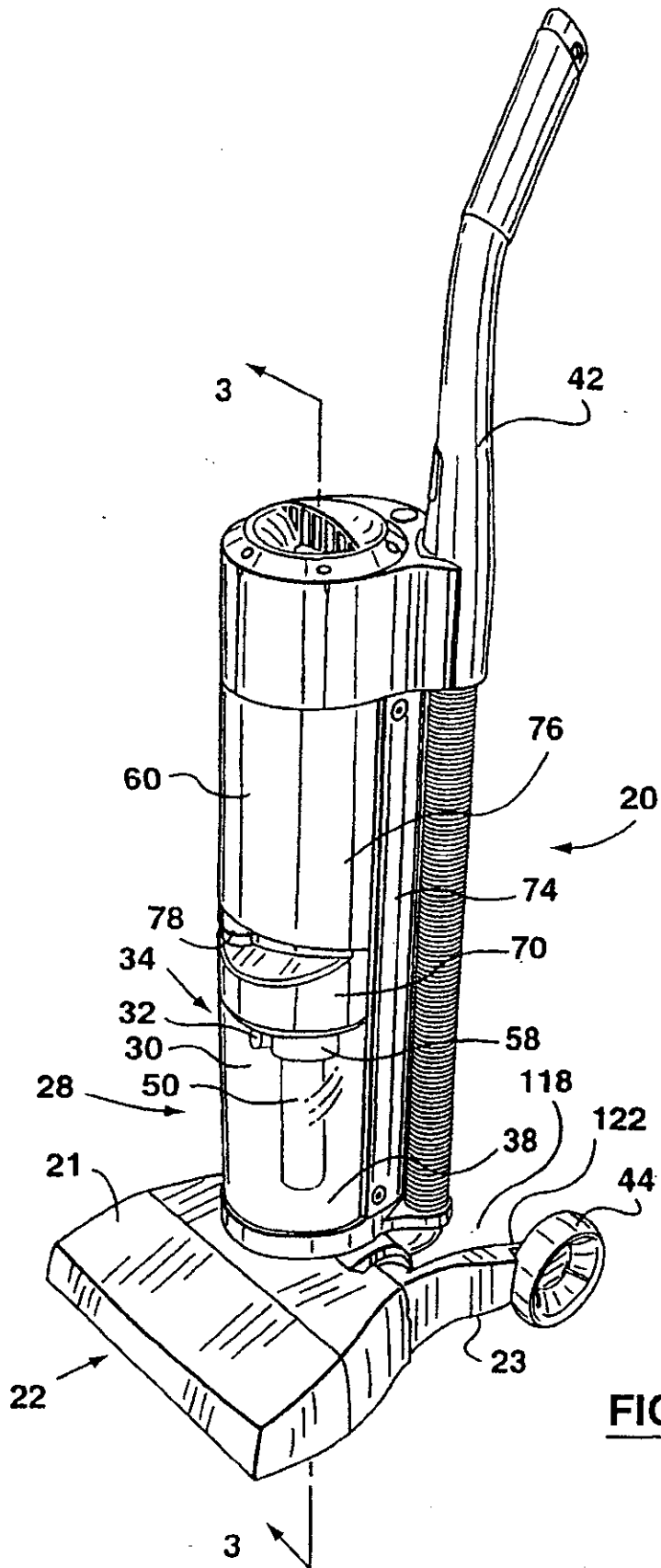
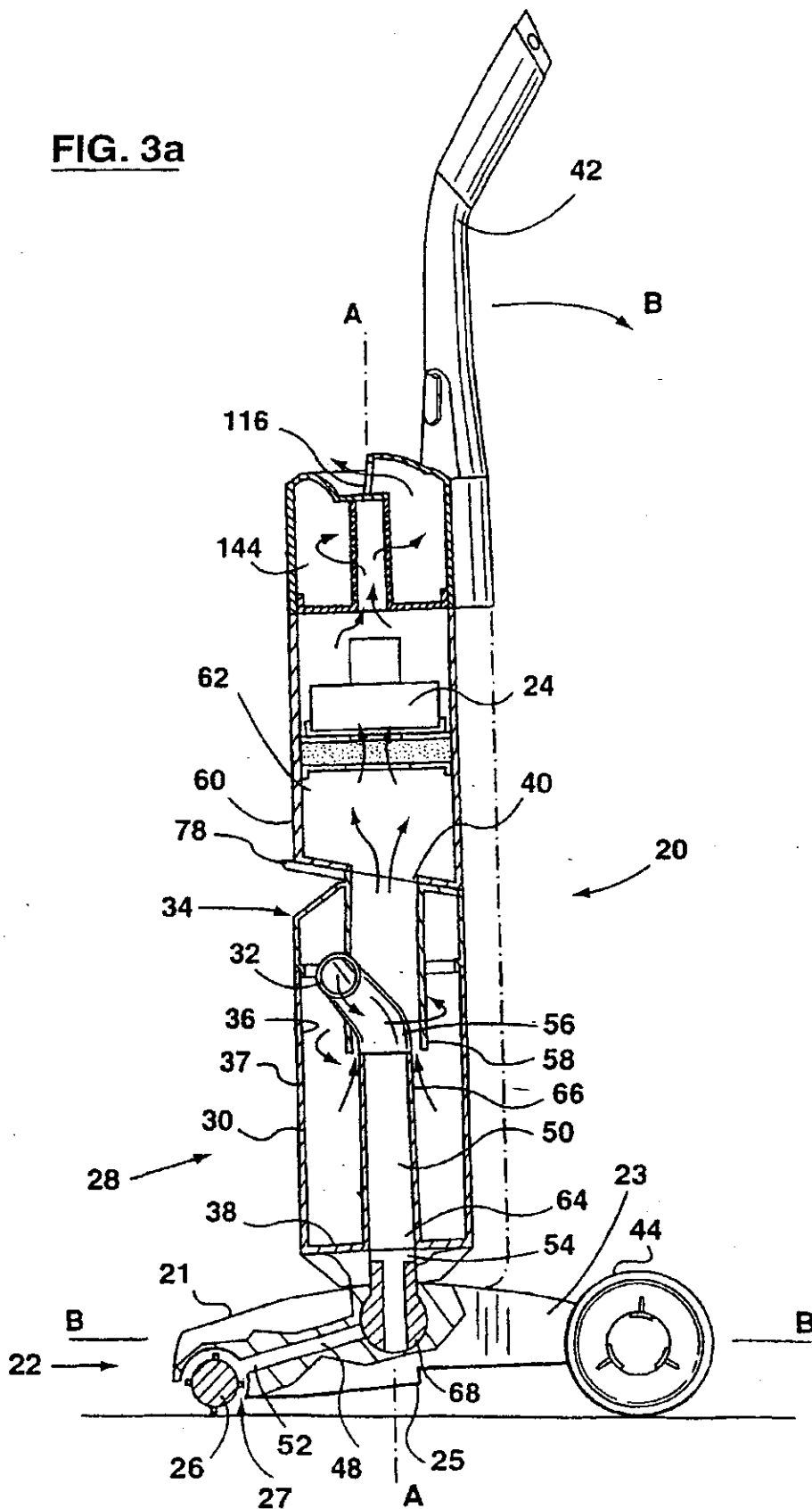

FIG. 3

FIG. 3a



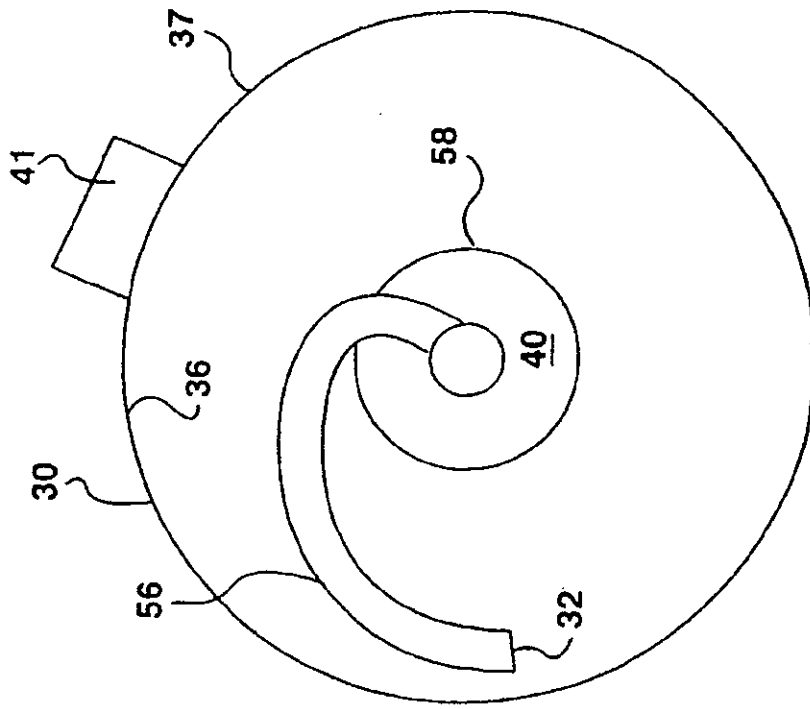

FIG. 5

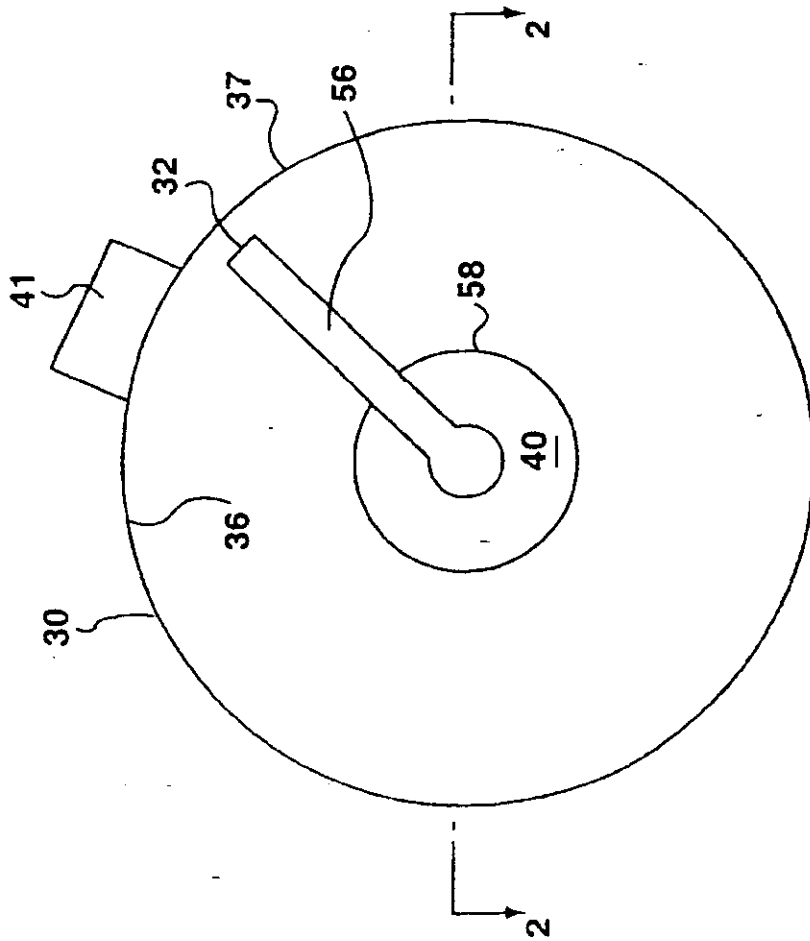

FIG. 4

FIG. 7

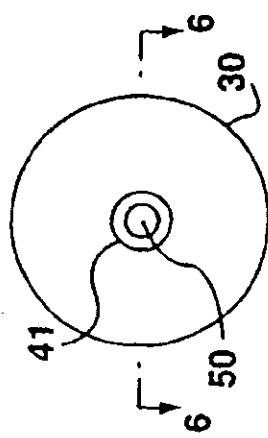

FIG. 9

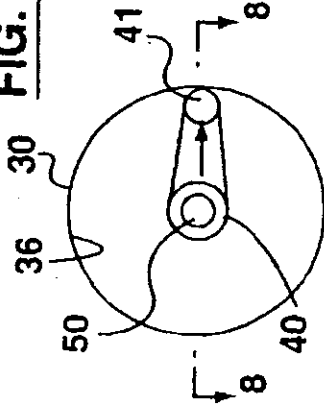

FIG. 11

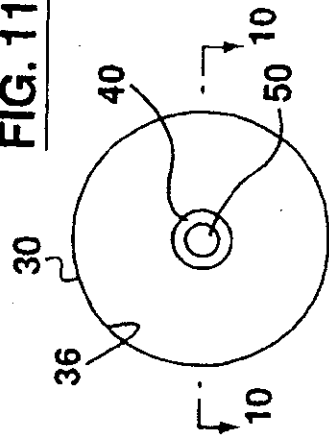

FIG. 6

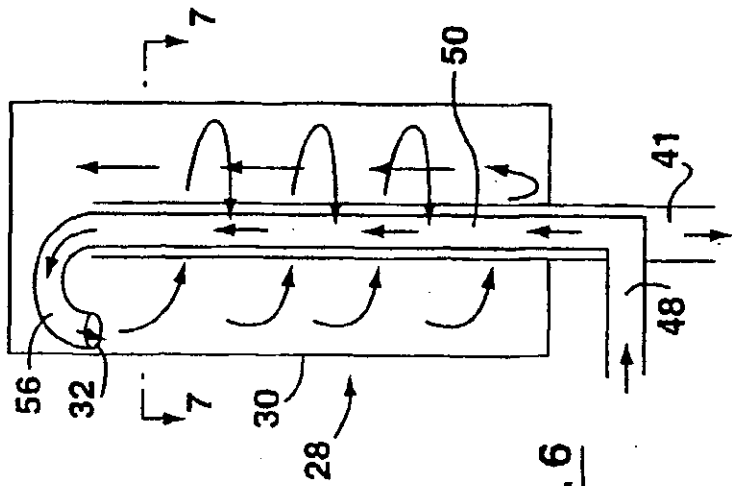

FIG. 8

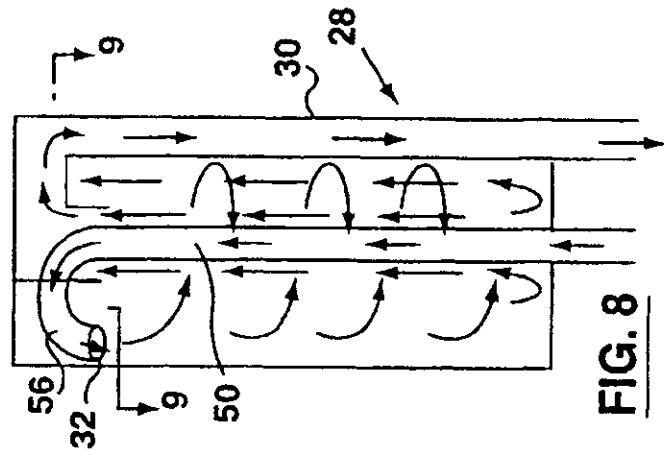

FIG. 10

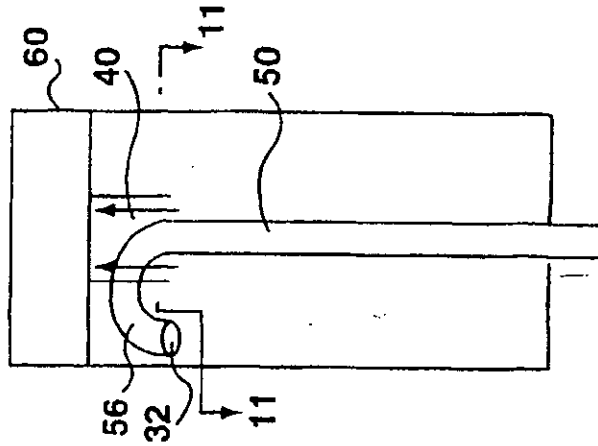

FIG. 13

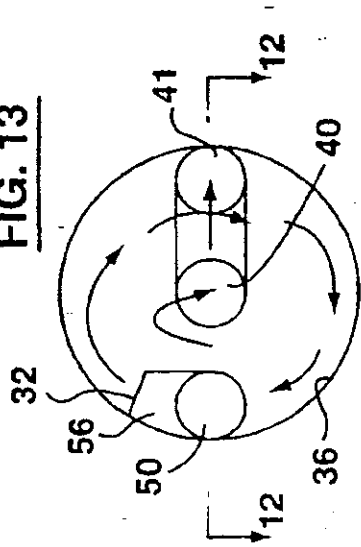

FIG. 15

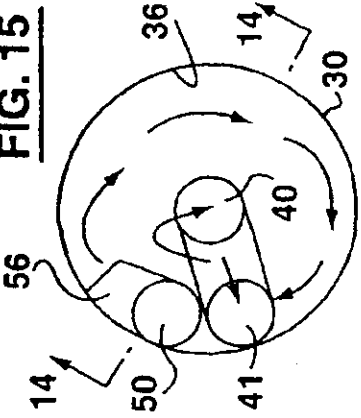

FIG. 17

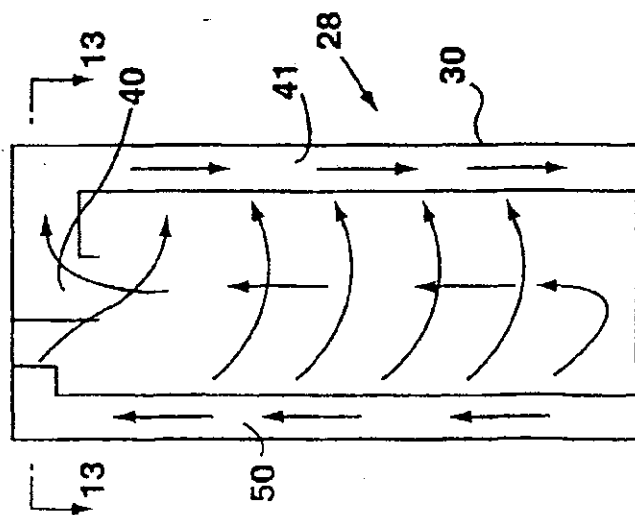
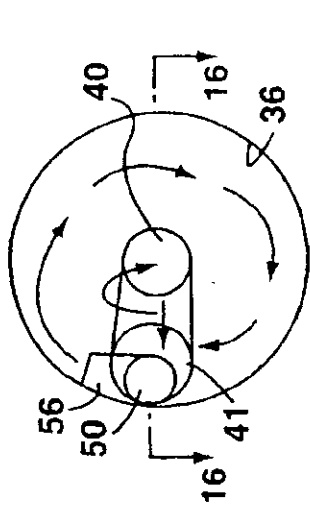

FIG. 12

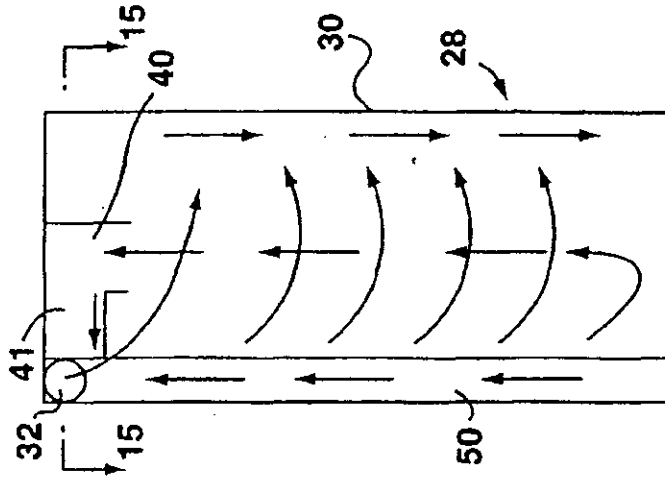

FIG. 14

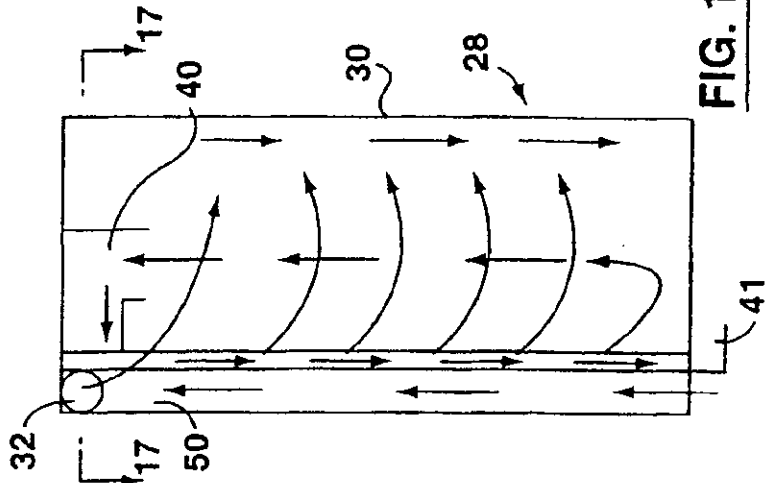
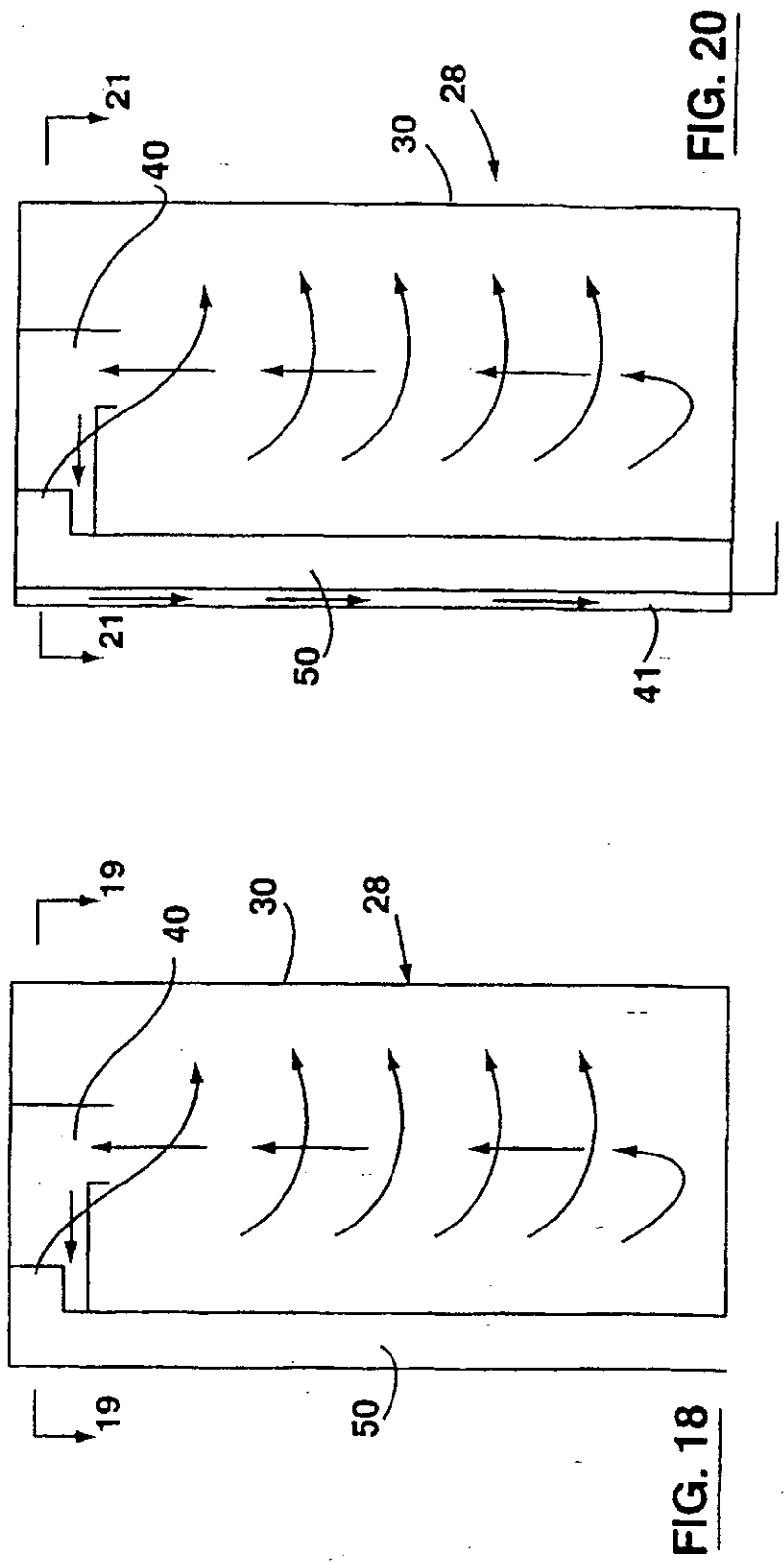
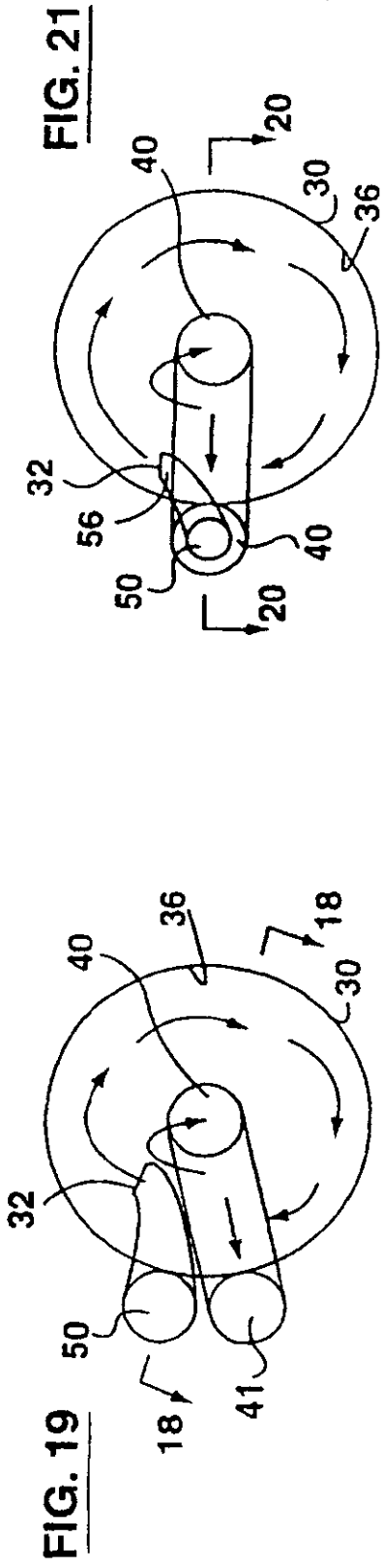

FIG. 16



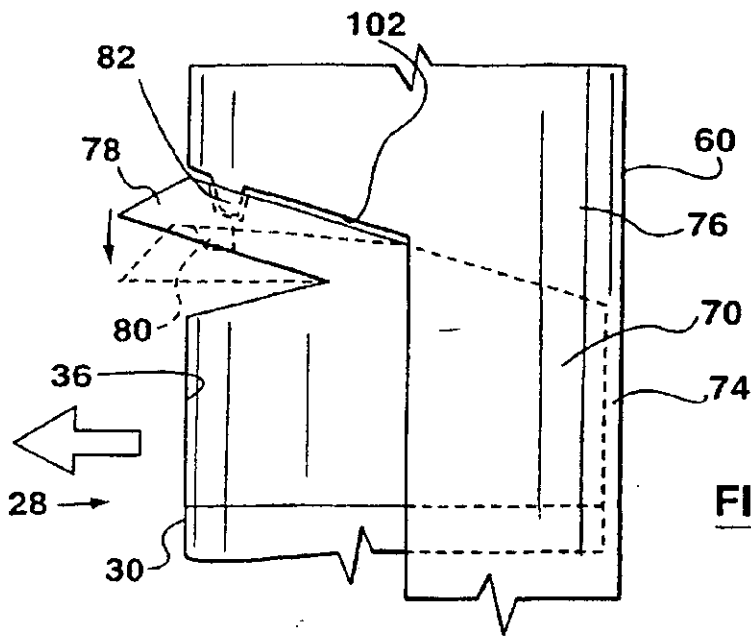

FIG. 22

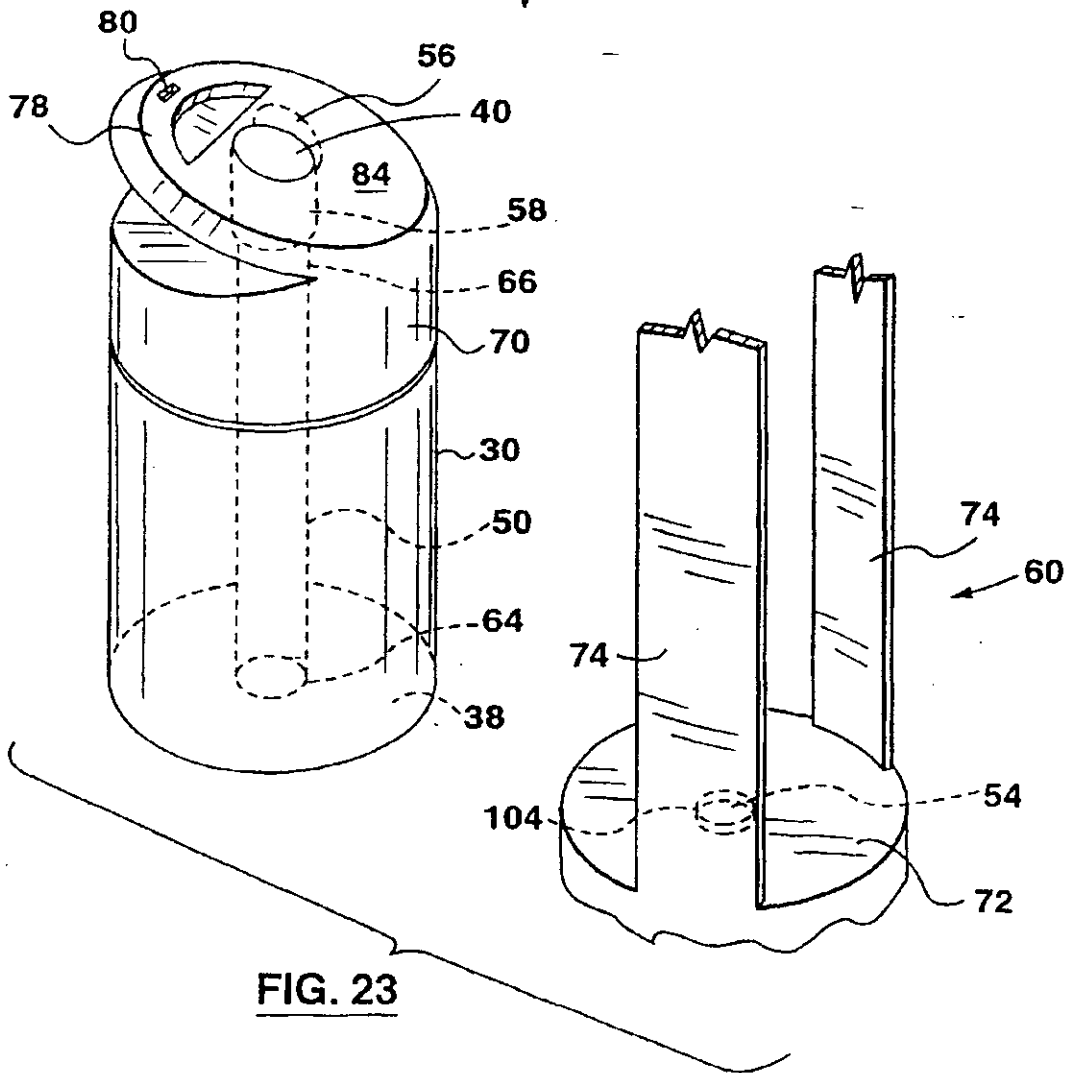

FIG. 23

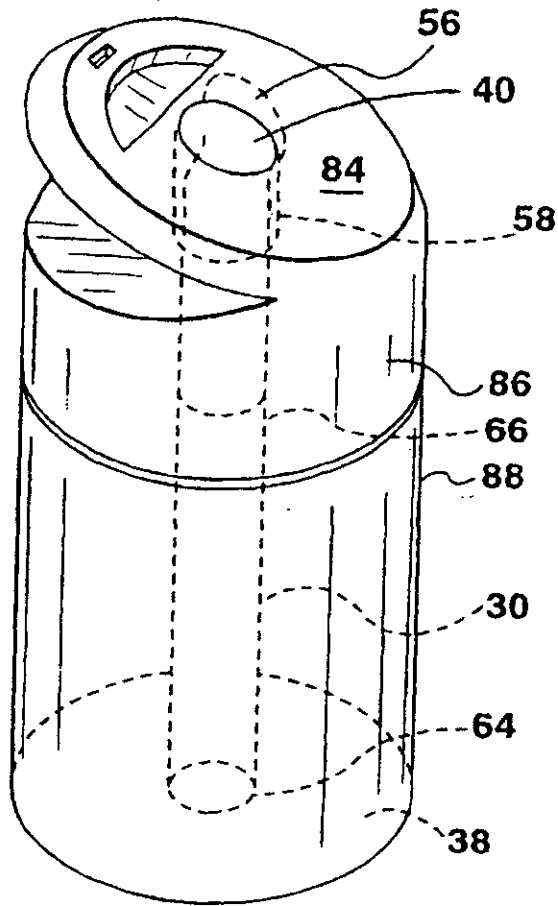

FIG. 24

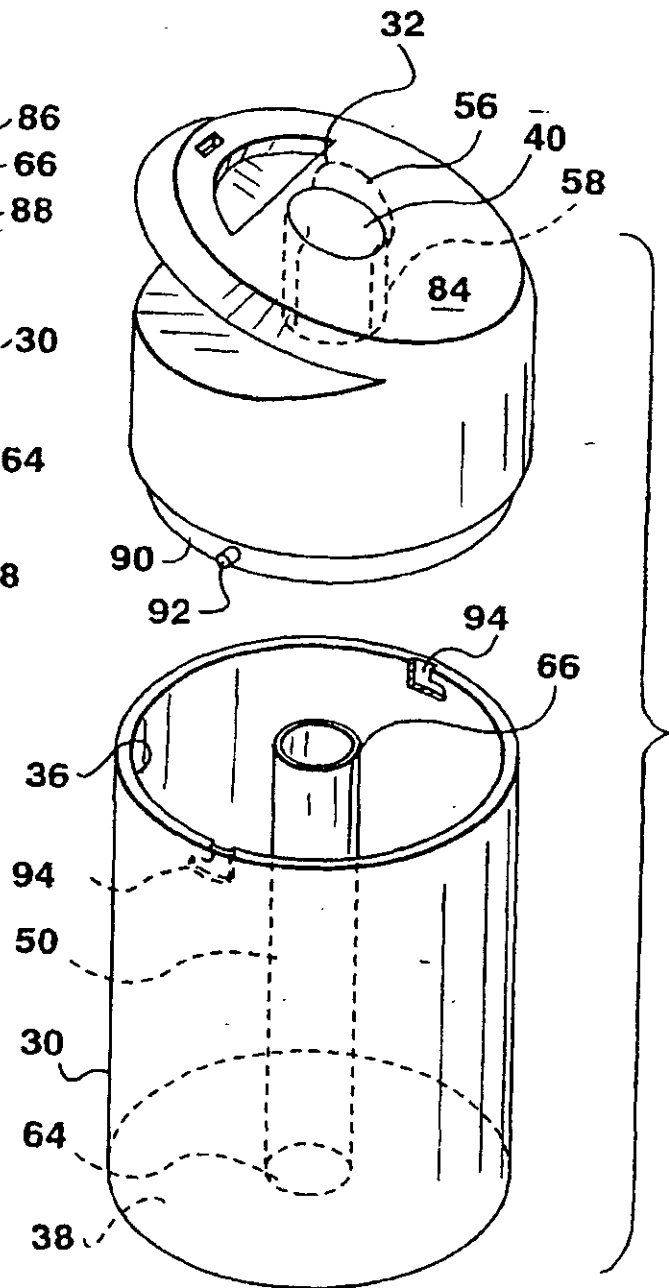
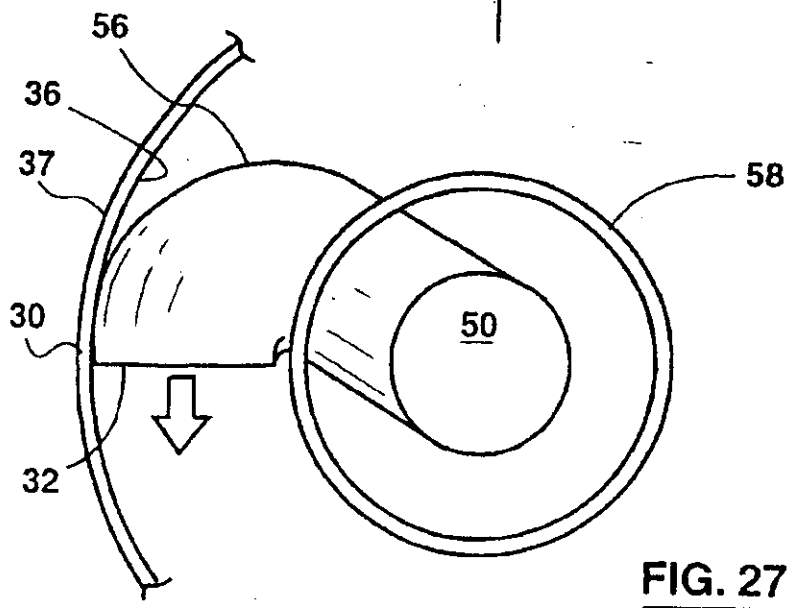
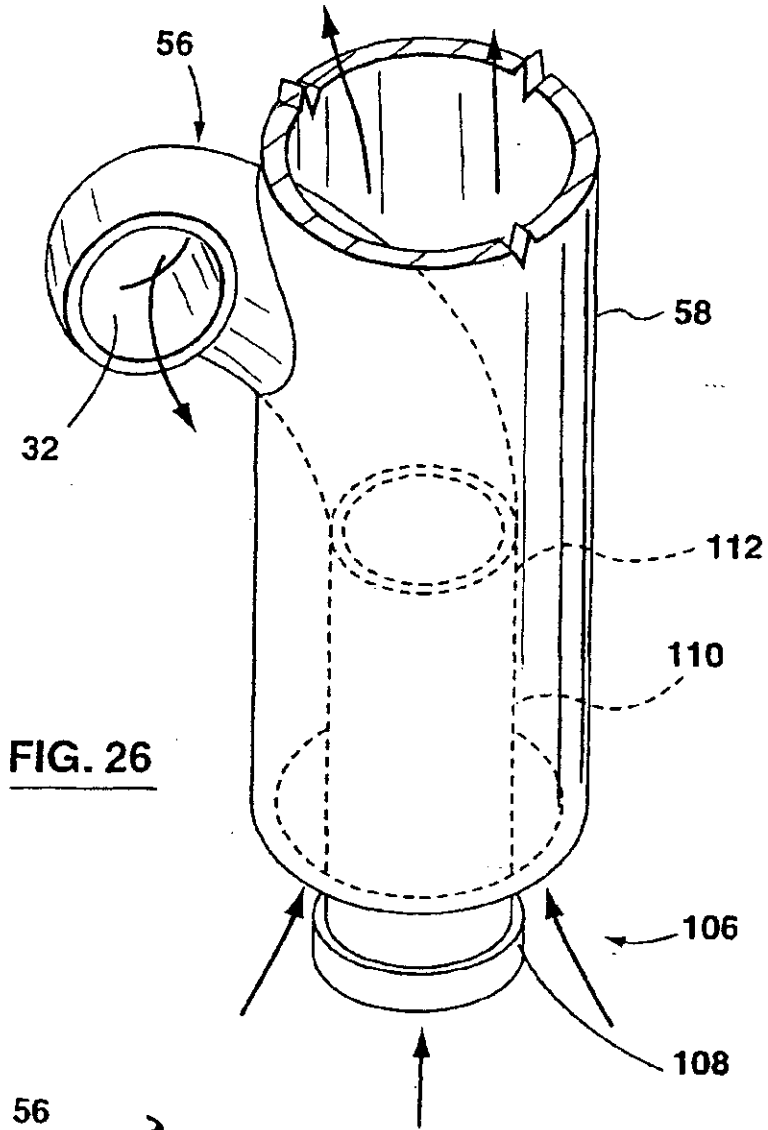

FIG. 25



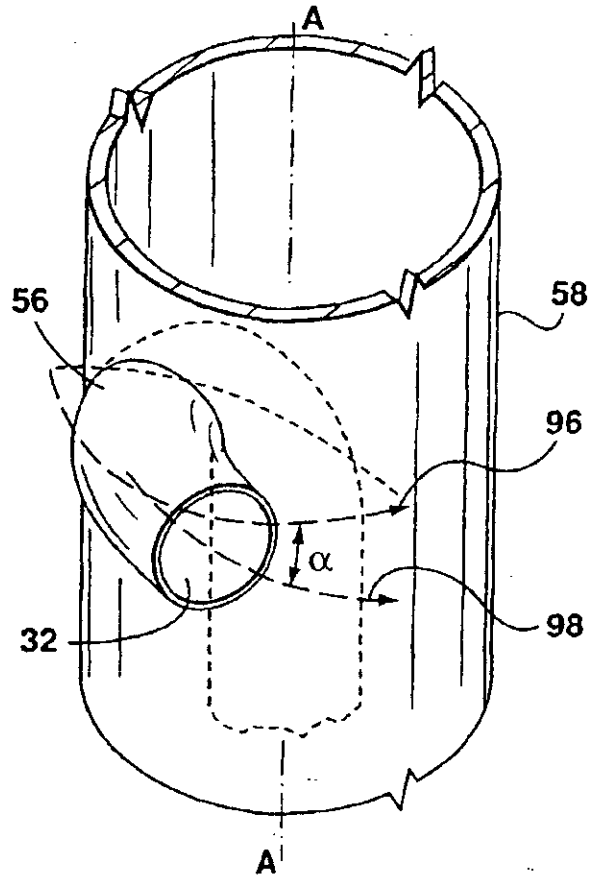

FIG. 28

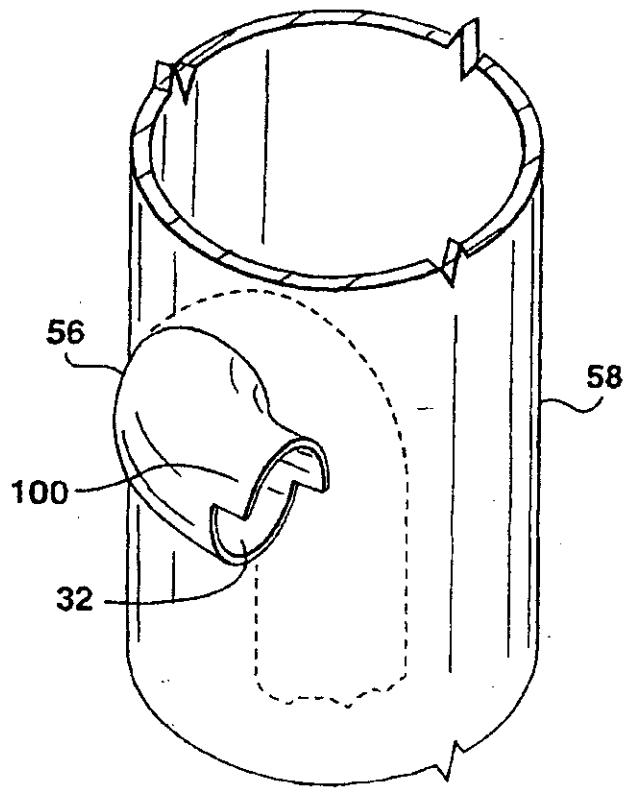

FIG. 29

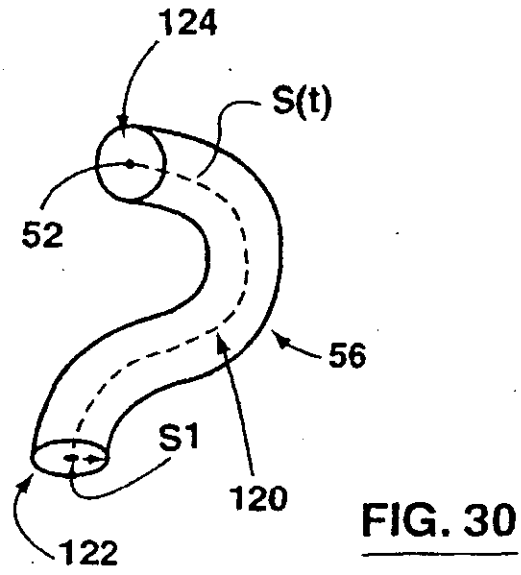

FIG. 30

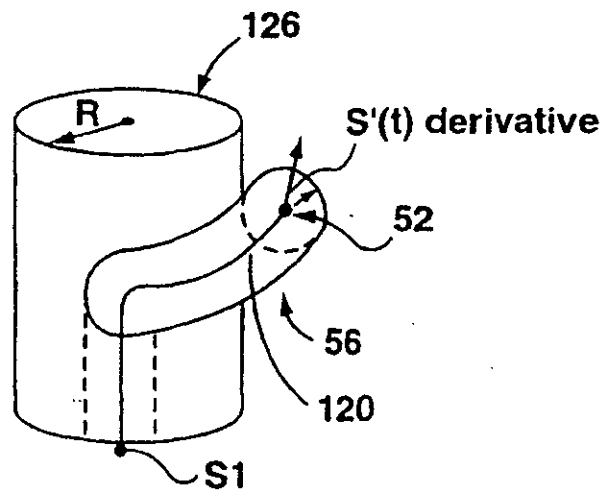

FIG. 30a